



## G 10ST

### DISC GRINDER, SNAP SWITCH



Capacity: Wheel Dia.	100mm (4")
Hole Dia.	16mm (5/8")
Spindle Thread	M10 x 1.5
Power Input	720W
No-load Speed	12,000/min.
Overall Length	262mm(10-5/16")
Weight	1.5kg (3.3 lbs.)
Standard Accessories	Depressed Center Wheel, Wrench, Side Handle

## PDA-100D

### DISC GRINDER, SNAP SWITCH



\*No depressed center wheel and Side Handle in actual unit

Capacity: Wheel Dia.	100mm
Hole Dia.	16mm
Spindle Thread	M10x1.5
Voltage	110V
Power Input	620W
No Load Speed	12,000rpm
Overall length	254mm
Weight	1.7kg
Switch Type	Snap
Standard Accessories	Wrench

## PDA-100K

### DISC GRINDER, SNAP SWITCH



110V  
\*No depressed center wheel and Side Handle in actual unit

Capacity: Wheel Dia	100mm
Hole Dia	16mm
Spindle Thread	M10 x 1.5
Voltage	220V / 110V
Power Input	705W
No Load Speed	12,000/min
Overall Length	258mm
Weight	1.5kg
Standard Accessories	Wrench

## PDA-100M

### DISC GRINDER, SNAP SWITCH



\*No depressed center wheel and Side Handle in actual unit

Capacity: Wheel Dia.	100mm (4")
Hole Dia.	16mm (5/8")
Spindle Thread	M10x1.5
Power Input	715W
No Load Speed	12,000/min
Overall Length	260mm
Weight	1.5kg (3.3 lbs)
Standard Accessories	Wrench

## G 10SN

### DISC GRINDER, SLIDE SWITCH



\*No depressed center wheel and Side Handle in actual unit

Capacity: Wheel Dia.	100mm (4")
Hole Dia.	16mm (5/8")
Spindle Thread	M10 x 1.5
Power Input	840W
No Load Speed	10,000/min
Overall Length	259mm (10-3/16")
Weight	1.6kg (3.5 lbs)
Standard Accessories	Wrench

## G 10SQ

### DISC GRINDER, PADDLE SWITCH



\*No depressed center wheel and Side Handle in actual unit

Capacity: Wheel Dia.	100mm (4")
Hole Dia.	16mm (5/8")
Spindle Thread	M10 x 1.5
Power Input	840W
No Load Speed	10,000/min
Overall Length	273mm (10-3/4")
Weight	1.6kg (3.5 lbs)
Standard Accessories	Wrench

## G 13SB3

### DISC GRINDER, SLIDE SWITCH



\*No depressed center wheel and Side Handle in actual unit

Capacity: Wheel Dia.	125mm (5")
Hole Dia.	22.23mm (7/8")
Spindle Thread	M14 x 2
Power Input	1,300W
No-load Speed	11,000/min.
Overall Length	283mm (11-9/16")
Weight	1.9kg (4.2 lbs)
Standard Accessories	Wrench

## G 13SE2

### DISC GRINDER, PADDLE SWITCH



\*No depressed center wheel and Side Handle in actual unit

Capacity: Wheel Dia	125mm (5")
Hole Dia	22mm (7/8")
Spindle Thread	M14 x 2
Power Input	1200W
No Load Speed	11,000/min
Overall Length	321mm (12-5/8")
Weight	1.9kg (4.2 lbs)
Standard Accessories	Wrench

## G 18SS

### DISC GRINDER, TRIGGER SWITCH



\*No depressed center wheel and Side Handle in actual unit

Capacity: Wheel Dia.	180mm (7")
Hole Dia.	22.23mm (7/8")
Spindle Thread	M14 x 2
Power Input	2,000W
No-load Speed	8,500/min.
Overall Length	463mm (18-7/32")
Weight	4.3kg (9.5 lbs)
Standard Accessories	Wrench

## G 18SH2

### DISC GRINDER, TRIGGER SWITCH



\*No depressed center wheel and Side Handle in actual unit

Capacity: Wheel Dia.	180mm (7")
Hole Dia.	22mm (7/8")
Spindle Thread	M14 x 2
Power Input	2,000W
No Load Speed	8,500/min
Overall Length	463mm (18-7/32")
Weight	4.3kg (9.5 lbs)
Standard Accessories	Side Handle, Wrench

## G 18SW2

### DISC GRINDER, TRIGGER SWITCH



\*No depressed center wheel and Side Handle in actual unit

Capacity: Wheel Dia.	180mm (7")
Hole Dia.	22.23mm (7/8")
Spindle Thread	M14 x 2
Power Input	2,200W
No-load Speed	8,500/min.
Overall Length	469mm (18-1/2")
Weight	4.9kg (10.8 lbs)
Standard Accessories	Wrench

## G 18SE3

### DISC GRINDER, TRIGGER SWITCH



\*No depressed center wheel and Side Handle in actual unit

Capacity: Wheel Dia.	180mm (7")
Hole Dia.	22.23mm (7/8")
Spindle Thread	M14 x 2
Power Input	2,300W
No-load Speed	8,500/min.
Overall Length	478mm (18-13/16")
Weight	5.0kg (11.0 lbs)
Standard Accessories	Wrench

## G 18MR

### DISC GRINDER, TRIGGER SWITCH, ALUMINUM



\*No depressed center wheel and Side Handle in actual unit

Capacity: Wheel Dia.	180mm (7")
Hole Dia.	22.23mm (7/8")
Spindle Thread	M14 x 2
Power Input	2,400W
No-load Speed	8,500/min.
Overall Length	492mm (19-3/8")
Weight	5.4kg (11.9 lbs)
Standard Accessories	Wrench

## G 23MR

### DISC GRINDER, TRIGGER SWITCH, ALUMINUM



Capacity: Wheel Dia.	230mm (9")
Hole Dia.	22.23mm (7/8")
Spindle Thread	M14 x 2
Power Input	2,400W
No-load Speed	6,600/min.
Overall Length	492mm (19-3/8")
Weight	5.4kg (11.9 lbs)
Standard Accessories	Wrench

**FSV 10SA**

**ORBITAL SANDER**



Capacity: Pad Size 92 x 184mm (3-5/8 x 7-1/4")  
 Orbit Dia. 2mm (3/32")  
 Power Input 180W  
 No Load Speed: Spindle 10,000/min  
 Orbit 20,000/min  
 Overall Length 184mm (7-1/4")  
 Weight 1.3kg (2.9 lbs)  
 Standard Accessories Sanding Paper, Dust Bag, Punch Plate

**P 20SB**

**PLANER**



Capacity: Cutting Width 82mm (3-1/4")  
 Max. Cutting Depth 1mm (1/32")  
 Power Input 570W  
 No-load Speed 15,000/min.  
 Overall Length 296mm (11-21/32")  
 Weight 2.5kg (5.5 lbs)  
 Standard Accessories Blade, Blade Setting Gauge, Guide, Wrench

**SB 8V2**

**SANDER BELT 3" 1020W**



Capacity: Belt Size 76 x 533mm (3 x 21")  
 Power Input 1,020W  
 No Load Speed 250-450m/min  
 (820-1,475ft/min)  
 Overall Length 318 (12-33/64")  
 Weight 4.3kg (9.7 lbs)  
 Standard Accessories Sanding Belt, Dust Bag

**SB 10V2**

**SANDER BELT 4" 1020W**



Capacity: Belt Size 100 x 610mm(4 x 24")  
 Power Input 1,020W  
 No-Load Belt Speed 240-420m/min  
 (800-1,375ft./min.)  
 Overall Length 363mm(14-19/64")  
 Weight 5.2kg(11.5lbs.)  
 Standard Accessories Sanding Belt, Dust Bag

**CJ 110MV**

**JIG SAW, VARIABLE SPEED W/ PENDULUM**



Capacity: Wood 110mm(4-5/6")  
 Mild Steel Plate 10mm(3/8")  
 Min. Cutting Radius 25mm(1")  
 Base Tilt Angle 45° Right/Left  
 Power Input 720W  
 Length of Stroke 26mm(1")  
 No load Speed 850-3,000/min  
 Overall Length 246mm(9-41/64")  
 Weight 2.2kg(4.9lbs)  
 Standard Accessories Blade, Splinter guard, Chip Cover, Dust Collection Adaptor, Carrying Case

**C 7SS**

**CIRCULAR SAW**



Capacity: Blade Dia. 190mm (7-1/2")  
 Max. Cut Depth: 90° 68mm (2-11/16")  
 45° 46mm (1-7/8")  
 Power Input 1,050W  
 No Load Speed 5,500/min  
 Overall Length 291mm (11-15/32")  
 Weight 3.4kg (7.5 lbs)  
 Standard Accessories Blade, Guide, Wrench

**C 9SA3**

**CIRCULAR SAW**



Capacity: Blade Dia 235mm(9-1/4")  
 Max Cut Depth 90°/45° 86mm / 65mm  
 Power Input 2,000W  
 No-load Speed 5,200/min  
 Overall Length 397mm(15-5/8")  
 Weight 7.2kg (15.9lbs)  
 Standard Accessories Blade, Side Handle, Guide, Bolt, Wrench, Adapter for dust collector, Short Lever

**C9**

**CIRCULAR SAW**



Capacity: Blade Dia. 235mm (9-1/4")  
 Max. Cut Depth: 90° 86mm (3-3/8")  
 45° 65mm (2-9/16")  
 Power Input 1,750W  
 No Load Speed 5,000/min.  
 Overall Length 376mm (14-9/32")  
 Weight 7.0kg (15.4 lbs)  
 Standard Accessories Blade, Side Handle, Guide, Wrench

**M 12SE**

**ROUTER**



Capacity: Collet Chuck 12mm (or 1/2")  
 Stroke 65mm (2-9/16")  
 Power Input 1,700W  
 No Load Speed 22,000/min.  
 Weight 5.3kg (11.7lbs.)  
 Standard Accessories Parallel Guide, Template Guide, Wrench

**M 12SA2**

**ROUTER**



Capacity: Collet Chuck 12mm (1/2")  
 Stroke 65mm (2-9/16")  
 Power Input 1,700W  
 No Load Speed 22,000/min  
 Weight 6.2kg (13.7 lbs)  
 Standard Accessories 2 Collet Chucks, Centering Gauge, Straight Guide, Template Guide, Template Guide Adapter, Dust Guide, Dust Guide Adapter, Wrench

**M 12VE**

**ELECTRONIC ROUTER**



Capacity: Collet Chuck 12mm (or 1/2")  
 Power Input 2,000W  
 No Load Speed 8,000-22,000/min.  
 Stroke 65mm  
 Weight 5.3kg (11.7lbs.)  
 Standard Accessories Parallel Guide, Template Guide, Wrench

**SP 18SB**

**POLISHER**



Capacity: Wool Bonnet 180mm (7")  
 Spindle Thread M14 x 2, or M16 x 2 or U5/8-11  
 Power Input 705W  
 No Load Speed 2,000/min  
 Overall Height 226mm(8-9/16")  
 Weight 2.1kg (4.6 lbs)  
 Standard Accessories Side Handle, Rubber Pad, Wool Bonnet, Wrench

**SAT-180**

**SANDER POLISHER**



Capacity: Sanding Disc 180mm (7")  
 Wool Bonnet 180mm (7")  
 Spindle Thread M14 x 2 or U5/8-11  
 Power Input 750W  
 No Load Speed Lo:1,900/min. Hi:3,400/min  
 Overall Length 395mm (15-9/16")  
 Weight 2.9kg (6.4 lbs)  
 Standard Accessories Side Handle, Rubber Pad, Wool Bonnet, Sanding Disc, Wrench

**SP 18VA**

**POLISHER-SANDER**



Capacity: Sanding Disc 180mm (7")  
 Wool Bonnet 180mm (7")  
 Spindle Thread M14 x 2 or U5/8-11  
 Power Input 1,250W  
 No Load Speed 0-3,400/min  
 Overall Length 415 (16-19/36")  
 Weight 2.8kg (6.4 lbs)  
 Standard Accessories Side Handle, Rubber Pad, Wool Bonnet, Types of Sanding Disc, Wrenches



**RH 650V**

**HEAT GUN**



Power Input	2,000W
Air flow in the dir.	I 250 - 500 l / min
Air flow in the dir.	II 250 - 500 l / min
The temperature in the dir.	I 50
The temperature in the dir.	II 50 - 650
outer diameter nozzle	34.5 mm
Dimensions	250 x 90 x 240mm
Weight	0.79 kg

**RB 40SA**

**BLOWER**



Capacity: Air Pressure	5.5 kPa
Air Volume Flow	3.8m3/min
Power Input	550W
No Load Speed	16,000/min
Overall Length	447mm (17-19/32")
Weight	1.7kg
Standard Accessories	Nozzle, Dust Bag

**RP35VB**

**DUST EXTRACTOR**



Capacity: Air Vacuum	25.5 lPa in Air Pressure
Air Volume Flow	3.5 m3/min.
Tank and its Resin	
Effective Dust Volume	Dry: 25 Liter / Wet: 22 Liter
Power Input	1,200W
Insulation	Grounded
Interlocking electric outlet	100 to 2,300W
Dimensions	410 x 435 x 539mm
Weight	8.4kg
Standard Accessorie	Hose Joint Handle, Hose (inner Dia 38mm x Length 3m), Nozzle for Fluid, Crevice Nozzle, Wet nozzle, Brush, Extension Pipe, Adapter for Power Tools, Pipe Holder

**DV 18V**

**IMPACT DRILL**



Drill Chuck	1.5-13mm (1/16-1/2")
Capacity: Concrete	Hi:13mm (1/2") Lo:18mm (11/16")
Steel	Hi:8mm (5/16") Lo:13mm (1/2")
Power Input	690W
No Load Speed	Hi:0-3,000/min Lo:0-1,000/min
Full Load Impact Rate	Hi:27,300/min Lo:8,400/min
Overall Length	333mm (13-1/8")
Weight	20kg (4.4 lbs)
Standard Accessories	Side Handle, Depth Gauge, Carrying Case, Chuck Wrench

**DM 20V**

**MASONRY DRILL**



Drill Chuck	1.5-13mm (1/16-1/2")
Capacity: Concrete	Hi:13mm (1/2") Lo:20mm (3/4")
Steel	Hi:8mm (5/10") Lo:13mm (1/2")
Wood	40mm (1-9/16")
Power Input	790W
No Load Speed	Hi:0-3,000/min Lo:0-1,000/min
Full Load Impact Rate	Hi:18,000/min Lo:7,650/min
Overall Length	390 (15-23/65")
Weight	2.5kg (5.5 lbs)
Standard Accessories	Side Handle, Depth Gauge, Carrying Case

**DH22PG**

**HAMMER, ROTARY, SDS-plus, 2-MODE**



Capacity:	
Concrete: Drill Bit	22mm (7/8")
Wood	24mm (15/16")
Mild Steel	13mm (1/2")
Power Input	620W
Bit Shank	SDS-plus
No Load Speed	0-1,500/min
Full Load Impact Rate	0-6,200/min
Overall Length	289mm (11-3/8")
Weight	1.9kg (4.2 lbs)
Standard Accessories	Side Handle, Depth Gauge, Carrying Case

**DH 24PB3**

**HAMMER, ROTARY, SDS-plus, 2-MODE**



Capacity:	
Concrete Drill Bit	24mm (15/16")
Core Bit	50mm (2")
Mild Steel	13mm (1/2")
Power Input	800W
Bit Shank	SDS-plus
No-load Speed	0-1,050/min.
Full-load Impact Rate	0-4,600/min.
Overall Length	351mm (13-13/16")
Weight	2.3kg (5.1 lbs.)
Standard Accessories	Side Handle, Depth Gauge, Carrying Case

**DH 26PC**

**26mm (1") ROTARY HAMMER**



Capacity:	
Concrete: Drill Bit	3.4-26mm (1/8"-1")
Core Bit	25-50mm (1"-2")
Mild Steel	13mm (1/2")
Wood	32mm (1-1/4")
Power Input	830W
Bit Shank	SDS-plus
No Load Speed	0-1,100/min
Full Load Impact Rate	0-4,300/min
Overall Length	367mm (14-7/16")
Weight	2.8kg (6.2 lbs)
Standard Accessories	Side Handle, Depth Gauge, Carrying Case

**DH 28PCV**

**28mm (1-1/8") ROTARY HAMMER**



Capacity:	3.4-28mm (1/8"-1-1/8")
Concrete: Drill Bit	25-50mm (1"-2")
Core Bit	13mm (1/2")
Mild Steel	32mm (1-1/4")
Wood	850W
Power Input	SDS-plus
Bit Shank	0-1,100/min
No Load Speed	0-4,300/min
Full Load Impact Rate	367mm (14-7/16")
Overall Length	2.9kg (6.4 lbs)
Weight	Side Handle, Depth Gauge,
Standard Accessories	Carrying Case

**DH 30PC2**

**SDS+ ROTARY HAMMER**



Capacity:	
Concrete: Drill Bit	30mm (1-3/16")
Core Bit	90mm (3-17/32")
Mild Steel	13mm (1/2")
Wood	32mm (1-1/4")
Power Input	850W
Bit Shank	SDS-Plus
No Load Speed	0-850/min
Full Load Impact Rate	0-3,700/min
Overall Length	355mm (14")
Weight	4.3kg(9.5 lbs)
Standard Accessories	Side Handle, Depth Stopper, Syringe, Carrying Case, Dust Cap
3 mode	Hammer Drilling, Drilling only, Hammering only

**DH 38SS**

**HAMMER, ROTARY, HEX, 2-MODE**



Capacity:	
Concrete: Drill Bit	38mm (1-1/2")
Core Bit	105mm (4-1/8")
Power Input	950W
Bit Shank	Hexagon
No Load Speed	620/min
Full Load Impact Rate	2,800/min
Overall Length	430mm (16-15/16")
Weight	6.4kg (14.1 lbs)
Standard Accessories	Side Handle, Carrying Case

**DH 45MR**

**HAMMER, ROTARY, SDS Max, 2-MODE**



Capacity:	
Concrete Drill Bit	45mm (1-3/4")
Core Bit	125mm (4-29/32")
Power Input	1,200W
Bit Shank	SDS Max
No Load Speed	120-140/min
Full Load Impact Rate	1,200-2,500/min
Overall Length	500mm (19-11/16")
Weight	8.0kg (17.6 lbs)
Standard Accessories	Side Handle, Depth Stopper, Grease Pack, Wrenches, Carrying Case
2 Mode	Hammer Drilling, Hammering Only

**DH 45ME**

**45mm (1-3/4") ROTARY HAMMER**



Capacity: Drill Bit 45mm (1-3/4")  
Core Bit 125mm (4-29/32")  
Power Input 1,500W  
Bit Shank SDS max  
No Load Speed 220V : 120-310/min  
Full Load Impact Rate 220V : 1,200-2,950/min  
Overall Length 535mm (21-1/16")  
Weight 9.0kg (19.8 lbs)  
Standard Accessories Side Handle, Stopper, Rotary Hammer Grease A, Carrying Case

**DH 52ME**

**52mm (2-1/16") ROTARY HAMMER**



Capacity: Drill Bit 52mm (2-1/16")  
Core Bit 160mm (6-1/4")  
Power Input 1,500W  
Bit Shank SDS max  
No Load Speed 220V : 110-280/min  
Full Load Impact Rate 220V : 1,000-2,400/min  
Overall Length 585mm (23-1/32")  
Weight 11.0kg (24.2 lbs)  
Standard Accessories Side Handle, Stopper, Rotary Hammer Grease A, Carrying Case

**PR 38E**

**HAMMER, ROTARY, HEX, 2-MODE**



Capacity:  
Concrete: Drill Bit 38mm (1-1/2")  
Core Bit 105mm (4-1/8")  
Power Input 1,050W  
Bit Shank Hexagon  
No Load Speed 400/min  
Full Load Impact Rate 3,000/min  
Overall Length 416mm (16-3/8")  
Weight 7.5kg (16.5 lbs)  
Standard Accessories Side Handle, Dust Cover, Wrenches, Oil Feeder, Carrying Case

**C 12RSH**

**SLIDE COMPOUND MITER SAW**



Capacity: Blade Dia. 305mm (12")  
(H x W) Cross Cut: 0 107x312mm (4-3/16 x 12-1/4")  
Compound: 70x220mm (2-3/4 x 8-21-32")  
Miter 450 and Bevel 450  
Bevel 450 Left  
Power Input 1,600W  
No Load Speed 3,800/min  
Miter Angle: Right: 0-570 Left: 0-460  
Bevel Angle: Right: 0-450 Left: 0-450  
Positive Miter Angle Stop 0, 15, 22.5, and 45 0  
Dimensions 595x930x710mm  
Weight 23kg (63.9 lbs)  
Standard Accessories Blade, Dust Bag, Vise Ass'y, Box Wrench

**CE 16SA**

**SHEAR**



Capacity : Steel 1.6mm (16ga.)  
Stainless 1.2mm (18ga.)  
Min. Cutting Radius 25mm (1")  
Power Input 400W  
No Load Speed 4,700/min.  
Overall Length 250mm (9-7/8")  
Weight 1.7kg (3.7lbs.)  
Standard Accessories Blade Set, Thickness Gauge, Hex. Bar Wrench

**CN 16SA**

**NIBBLER**



Capacity : Steel 1.6mm (16ga.)  
Stainless 1.2mm (18ga.)  
Cutting Width 5mm (3/16")  
Min. Cutting Radius 40mm (1-9/16")  
Power Input 400W  
No Load Speed 2,300/min.  
Overall Length 250mm (9-7/8")  
Weight 1.6kg (3.5lbs.)  
Standard Accessories 2 Hex. Bar Wrenches

**CM 12Y**

**305mm METAL / CONCRETE CUTTER**



Capacity: Wheel Dia. 305mm (12")  
Max. Cut Depth 100mm (4")  
Cut Depth per one cutting 50mm (1-31/32")  
Power Input 2,400W  
No Load Speed 5,000/min.  
Arbor 22mm (7/8")  
Overall Length 633mm (24-15/16")  
Weight 11.5kg (25.3lbs.)  
Standard Accessories Dust Collection Adapter, Protective Goggles, Wrench

**CM 75EBP**

**355mm Engine Cutter**



Displacement 75.0 mL (cc) Max. Speed 5,100/min or more  
Max Power Output 3.9kw Max. Thickness 4.0mm  
Decomp. System Yes Outer Diameter 355mm (14")  
Fuel Tank Capacity 1.100mL Arbor Hole Dia. 20mm  
Wheel Type Type 41 Max. Speed 5,100/min or more  
Outer Diameter 355mm (14") Max. Thickness 4.0mm  
Arbor Hole Dia. 20mm (25.4mm with Adapter collar)

**CM 4ST**

**MARBLE CUTTER**



Capacity: Wheel Dia. 110mm (4-3/8")  
Max. Cut Depth 34mm (1-3/8")  
Power Input 1,300W  
No Load Speed 13,000/min  
Overall Length 214mm (8-27/64")  
Weight 2.9kg (6.4lbs.)  
Standard Accessories Wrench

**D 6SH**

**DRILL**



Chuck Capacity 0.5-6.5mm  
Capacity: Steel 6.5mm (1/4")  
Wood 9mm (3/8")  
Power Input 240W  
No Load Speed 4,500/min  
Overall length 206mm (8-1/8")  
Weight 0.9kg (2.0 lbs)  
Standard Accessories Chuck Wrench, Hook Stopper

**D 10VST**

**DRILL, VARIABLE SPEED REVERSIBLE**



Chuck Capacity 10mm (3/8")  
Capacity: Steel 10mm (3/8")  
Wood 25mm (1")  
Power Input 0-3,000/min  
No Load Speed 450W  
Overall length 227mm (8-15/16")  
Weight 1.2kg (2.6 lbs)  
Standard Accessories Chuck Wrench

**DV 13VSS**

**IMPACT DRILL**



Drill Chuck 1.5-13mm (1/16-1/2") Keyless  
Capacity: Concrete 13mm (1/2")  
Steel 13mm (1/2")  
Wood 20mm (3/4")  
Power Input 550W  
No Load Speed 0-2,900/min  
Full Load Impact Rate 29,000/min  
Overall Length 270mm (10-19/32")  
Weight 1.4 kg (3.1 lbs)



**H 60MC**

**DEMOLITION HAMMER**



Power Input 1,250W  
 Full Load Impact Rate 1,600/min  
 Bit Shank SDS Max  
 Overall Length 570mm (22-7/16")  
 Weight 10.2kg (22.5 lbs)  
 Standard Accessories Side Handle, Carrying Case

**H 90SE**

**DEMOLITION HAMMER, HEX**



Power Input 1,450W  
 Full Load Impact Rate 850/min.  
 Bit Shank 28.5mm (1-1/8") Hexagon  
 Overall Length 859mm (33-13/16")  
 Weight 32.0kg (70.5 lbs)  
 Standard Accessories Wrenches

**WH 14DSL**

**CORDLESS IMPACT DRIVER**



Capacity: Bolt 6 - 14mm (1/4 - 9/16")  
 High Tension Bolt 6 - 12mm (1/4 - 15/32")  
 Machine Screw 4 - 10mm (5/32 - 3/8")  
 Drive 6.35mm (1/4") Hex Bit Shank  
 Tightening Torque : Power mode 165Nm (1,460 in.-lbs)  
 Save mode 90Nm (800 in.-lbs)  
 Battery Voltage 14.4V  
 No Load Speed : Power mode 0 - 2,600/min.  
 Save mode 0 - 2,000/min.  
 Full Load Impact Rate 0 - 3,200/min.  
 Overall Length 161mm (6-11/32")  
 Weight 1.6kg (3.5 lbs.)  
 Standard Accessories 2 Batteries (BSL1430),  
 Charger (UC18YRSL), Battery Cover,  
 Carrying Case

**WR 14DL**

**IMPACT WRENCH**



Capacity: Bolt 10-16mm (3/8-5/8")  
 Capacity: High Tension Bolt 8-14mm (5/16-9/16")  
 Drive 12.7mm (1/2") Square Bit Shank  
 Tightening Torque 200Nm (1,770 in.-lbs)  
 Battery Voltage 14.4V  
 No Load Speed 0-2,300/min.  
 Full Load Impact Rate 0-3,000/min.  
 Overall Length 167mm (6-37/64")  
 Weight 1.5kg (3.3 lbs.)  
 Standard Accessories Battery (BCL1430),  
 Charger (UC18YRL),  
 Carrying Case

**WF 18DSL**

**18V CORDLESS AUTOMATIC SCREWDRIVER**



Drive 6.35mm (1/4") Hex Bit Shank  
 Capacity : Screw Size Size 4mm (5/32")  
 Screw Length 25 - 41mm (1 - 1-5/8")  
 Loading 50 screws  
 Battery Voltage 18V  
 No Load Speed 4,200/min.  
 Overall Length 379mm (14-15/16")  
 Weight 2.1kg (4.6lbs.)  
 Standard Accessories 2 Batteries (BSL1840),  
 Charger (UC18YFSL), Driver Bit,  
 Battery Cover, Carrying Case

**CL 18DSL**

**18V CORDLESS STUD CUTTER**



Capacity: Threaded Stud Size W3/8, W5/16, M10, M8, M6  
 Battery Voltage 18V  
 No Load Speed 30/min.  
 Overall Length 283mm (11-9/64")  
 Weight 3.2kg (7.1lbs)  
 Standard Accessories 2 Batteries (BSL1840 or BSL1830),  
 Charger (UC18YRSL),  
 M8 Cutter Set, M8 Trimmer,  
 Hexagon bar Wrench, Carrying Case

**CS 350A**

**CHAIN SAW**



Capacity: Bar Size 350mm (14")  
 Power Input 1,140W  
 Length of Stroke 29mm (1-1/8")  
 No-load Speed of Chain 450m/min. (1,475ft/min.)  
 Overall Length 641mm (25-1/4")  
 Weight 4.2kg (9.3 lbs)  
 Standard Accessories Oil Feeder, Wrench

**CS35Y**

**CHAINSAW 2000W**



Power Input\*1 220V  
 No Load Chain Speed 14.5m/s  
 Chain Pitch 3/8"  
 Chain Gauge 0.05"  
 Guide Bar Length 350mm (14")  
 Type of Guide bar Sprocket Nose  
 Oil Tank Capacity 150mL  
 Dimensions (L x W x H) 490 x 217 x 220mm  
 Dry Weight\*2 5.4kg (11.9 lbs)

**CG 40EAS**

**ENGINE BRUSHCUTTER**



Displacement 39.8mL (cc)  
 Max Power 1.2kW  
 Fuel Tank Capacity 1.0L  
 Dia. of Pipe 28mm  
 Dimensions(L x W x H) 1,795 x 670 x 400mm  
 Dry Weight 7.5kg

**CH 22EA2**

**HEDGE TRIMMER**



Engine Displacement 21.1cc  
 Max Power 0.65kW / 0.87hp  
 Blade Bar Length 500mm  
 Blade Pitch 30mm  
 Multi Position Rear Handle 5 position  
 Fuel Tank Capacity 300mL  
 Fuel Mix 50:1 (when mixed with Hitachi 2 stroke lubricant)  
 Spark Plug NGK (BPMR7A)  
 Sound Pressure Level 97dB(A)  
 Dry Weight 4.3kg  
 Product Dimensions 238mm(w) x 936mm (l) x 216mm (h)  
 Standard Accessories Blade bar cover, hex key & combi box spanner

# GEAR MOTOR

株式会社 日立産機システム

GA-SERIES



**Made in Japan**

## Features

- **Small size and light weight**
- **Long life**
- **Adopt double seal structure**
- **Set-up High-efficiency motor is available**
- **Output range: 0.4kW~11kW**
- **For medium loads (General purposes)**

**Suitable to medium impact loads.**

**It can operate at least 10-hours/day when constant loads or light impact loads are applied.**

## Application Examples

- **General purpose conveyor**
- **Metal working machine**
- **General machine tool**
- **Feed plant machine**

<b>MODEL</b>	<b>POWER</b>		<b>RATIO</b>	<b>OUTPUT RPM</b>
GA48-220-30	3HP	2.2KW	1:30	60
GA55-370-30	5HP	3.7KW	1:30	60
GA60-750-20	10HP	7.5KW	1:20	90



# HITACHI

## Inspire the Next

### BEBICON AIR COMPRESSOR

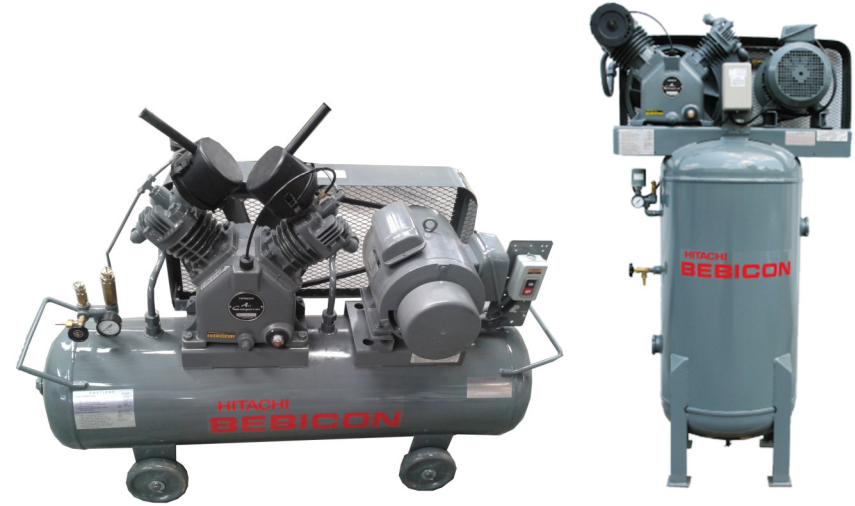

Model	Tank Type	Operating System	Motor Output (kW)	Maximum Pressure MPa	Cylinder Diameter (mm) x stroke (mm) x number of cylinders	Compressor speed (min <sup>-1</sup> )	Displacement (L/min)	Capacity at Maximum Pressure	Air Tank Capacity (L)	Power Source (PH)	Standard Accessories	External Dimensions Width x Depth x Height (mm)	Weight (Kg)	Noise Level dB[A]
<b>0.75U-9.5VS6A</b>	Horizontal	Automatic unloader type	0.75	0.93	50 x 65 x 1	990	126	80	60	1	Pressure Gauge, Safety valve, Hose joint, V-belt, Belt cover,	931x376x816	79	70
<b>0.75U-9.5V6A</b>										3			72	
<b>1.5U-9.5VS6A</b>	Horizontal	Automatic unloader type	1.5	0.93	72 x 65 x 1	970	257	165	80	1	Silencer stop valve, Air outlet 1/4BX1 for 0.75 & 1.5kW, 1/4BX2 for 2.2 kW, 1/4BX1 & 3/8BX1 for 3.7 & 5.5 kW 1/4BX1 & 3/4BX1 for 7.5 & 11kW 1BX 1 for 15 kW	1,173x380x867	102	72
<b>1.5U-9.5V6A</b>										3			90	
<b>2.2U-9.5VS6A</b>	Horizontal	Automatic unloader type	2.2	0.93	72 x 65 x 2	730	386	265	90	1		1,283x403x808	134	72
<b>5.5U-9.5V6A</b>	Horizontal	Automatic unloader type	5.5	0.93	L) 105x85x1 H) 60x85x1	1,080	795	630	150	3		1,470x482x979	203	76
<b>3.7P-14V6A</b>	Vertical	Pressure switch type	3.7	1.23/1.37	L) 90x85x1 H) 50x85x1	900	487	400	300	3	Pressure Gauge, Safety valve, Hose joint, V-belt, Belt cover, Silencer stop valve 3/8BX1 for 3.7 & 5.5 kW 3/4BX1 for 7.5 kW	957x590x1,732	260	75
<b>5.5P-14V6A</b>	Vertical	Pressure switch type	5.5	1.23/1.37	L) 105x85x1 H) 60x85x1	970	714	550	300	3		1,025x611x1,734	317	76

# HITACHI INDUCTION MOTOR

# HITACHI

Inspire the Next



Single Phase 4-Pole 1750RPM  
Open Drip-Proof, Class-E Insulation IP22  
Split Phase 220V~60Hz

#### FEATURES:

- Economical and High Efficiency
- Compact Size
- Switch Works Constantly

CODE	HP
EFOUKT-1/3	1/3HP

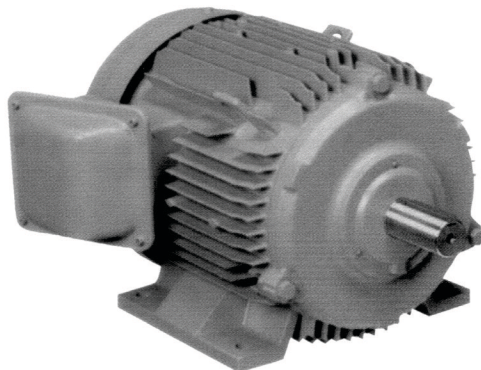

220V / 440V Dual Voltage, 3-Phase, 4-Pole,  
1750RPM, TEFC IP55, Class-B Insulation,  
Foot Mounted IEC Standard

#### FEATURES:

- Total enclosed with cooling fan  
(prevent any water droplets and dust)
- From 1/2HP-75HP(0.4kW-55kW)
- Aluminum Alloy Frame  
(light weight, effectively heat ventilation)
- IEC-standard, CE-mark and TÜV-mark
- Insulation Class F

CODE	HP	TERMINAL
TFOK-1	1HP	W/9 TERMINAL
TFOK-2	2HP	W/9 TERMINAL
TFOKK-40	40HP	W/12 TERMINAL

**Made in Thailand**



# Hitachi Lithium-ion Cordless Series

# HITACHI

Inspire the Next

## CS36DL Cordless Chain Saw Bare+Battery+Charger

**36V** **Li-ion** BATTERY



Battery Voltage	36V
Guide Bar Length	300mm
Chain Speed	8.3m/s
Type of Guide Bar	Sprocket Nose
Chain Pitch	9.52mm (3/8")
Overall Length	618mm
Weight	4.4kg
Standard Accessories* <sup>1</sup>	Battery (BSL3620 ), Charger (UC36YRSL), Chain Case, Round File, Chain Oil, Battery Cover

## CG18DSDL 18V Cordless Grasstrimmer+Battery+Charger



Battery Voltage	18V
Cutting Capacity Dia.	310mm (12")
No Load Speed of Trimmer	5,000/min.
Dimensions (L x W x H)	1,670 x 320 x 250mm (65-3/4" x 12-19/32" x 9-27/32")
Weight	4.3kg (9.5lbs.)
Standard Accessories	Battery (BSL1840 or BSL1830), Charger (UC18YRSL or UC18YGSL), Nylon Head, Eye Protector, Wrenches

## CG36DL Cordless Grass Cutter Bike Handle Bare+Battery+Charger

**36V** **Li-ion** BATTERY



Battery Voltage	36V
Cutting Capacity Dia.	310mm
No Load Speed of Trimmer	5,800 - 7,000/min.
Overall Length	1,900mm : CG36DL (L)
Weight	5.5kg : CG36DL (L)
Standard Accessories* <sup>1</sup>	Battery (BSL3620 ), Charger (UC36YRSL), Cover, Nylon Head, Shoulder Belt, Hanger Belt, Eye Protector, Wrenches, Battery Cover

## RB36DL Cordless Blower Bare+Battery+Charger

**36V** **Li-ion** BATTERY **BRUSH LESS MOTOR**



Battery Voltage	36V
Air Volume	680m <sup>3</sup> /h (800m <sup>3</sup> /h when turbo mode* <sup>2</sup> )
Air Velocity	45m/s (53m/s when turbo mode* <sup>2</sup> )
Overall Length	948mm
Weight	3.8kg
Standard Accessories* <sup>1</sup>	Battery(BSL3620), Charger(UC36YRSL), Nozzle, Battery Cover, Nozzle

\*<sup>2</sup> The turbo mode continues for 10 seconds

## UC36YRSL 14.4-36V Li-ion



Charging Voltage: 14.4 - 36V  
Weight: 0.50

**Li-ion** BATTERY

## BSL1830 Slide Lithium-ion Battery



Voltage 18V  
Capacity 3.0Ah

## BSL3626 Slide Lithium-ion Battery



Voltage 36V  
Capacity 2.6Ah

**36V** **Li-ion** BATTERY

## BL36200 36V Back Pack Power Supply



750 Wh **36V** **Li-ion** BATTERY

Battery: Assortment	Lithium-ion
Battery: Voltage	36V
Battery: Capacity	21Ah(750Wh)
Output Terminal	USB (A type)
Dimensions (L x W x H)	109 x 250 x 330mm
Weight: Back Pack Power Supply	6.3kg
Weight: Adapter	0.5kg
Weight: Carrier	1.0kg
Standard Accessories	Carrier, Charger (UC36YRSL), Adapter (with Cover), Arm Band, Knob Bolts, M5 Screws

High Capacity to provide longer runtime

Hitachi Koki Co., Ltd.

# HITACHI

Inspire the Next

## Electric chain hoist

## Suspension type

Single speed model

3 Phase 220V/440V 60Hz



### SINGLE PHASE

Model Name	1SH(1)
Rated Load (kg)	1,000
Standard Lift (m)	6
Hoisting Speed (m/min) 60Hz	2.8
Motor Output (kW) 60Hz	0.5
Link Chain : Dia. (mm)	Ø7.1
: No. of Falls	1
Rating	20%ED
Power Cord length	5m

## Motor Trolley 220V/440V 60Hz 3 Phase

### Plug-in Type Push Button (4PBSS)

(The control cable/push button is for single speed hoist)

Model Name	1ST	2ST	3ST
Working Load Limit (kg)	1,000	2,000	3,000
Traveling Speed (m/min) 60Hz	12.5	12.5	12.5
Motor Output (kW) 60Hz	0.08	0.16	0.24
Applicable Beam Width b (mm)	75-125	100-150	100-150
Rating	25%ED	25%ED	25%ED



Hoist type	5HM5		
Trolley type	5T5		
Capacity (t)	5		
Dimensions with respect to I-beam	T	U	C
(150×75×5.5)			
200×100×7			
250×125×7.5			
300×150×11.5	225	30	215
450×175×11	223	32	365
Approx. weight (kg)	745		

Approx. dimensions (mm)	L	12,000
	H	1,190
	A	955
	B	800
	M	455
	W	250/330
	K	—
	J	—
	φ d	90
	φ p	156/140(DRIVE SIDE/DRIVEN SIDE)
	a	58
	Min. curve radius (m)	3.0

